

Low-Power, Low Offset, Dual Comparators

FEATURES

- **Low Power Consumption: 0.6mA (TYP)**
- **Single Supply Voltage Range: 2V to 36V**
- **Dual Supplies Voltage Range: $\pm 1V$ to $\pm 18V$**
- **Low Offset Voltage: 1mV (TYP)**
- **Open Collector Output**
- **Low Input Bias Current: 25nA (TYP)**
- **Input Common-Mode Voltage Range to 0V**
- **Packages: SOP8, TSSOP8, MSOP8**
- **Operating Temperature Range: -40°C to $+125^{\circ}\text{C}$**

APPLICATIONS

- **Zero-Crossing Detectors**
- **RC Timers**
- **IR Receivers**
- **Threshold Detectors and Phase Discriminators**
- **Rotary Position Encoders**

PRODUCT DESCRIPTION

The TS2903 is a dual-channel high precision voltage comparator with a typical 1mV offset voltage. The device can be operated over a wide range of supply voltages. It can be used with a single supply or a dual-supply as long as the difference between the two supplies is from 2V to 36V.

The device has a special feature that allows the input common-mode voltage to be set to negative power rail.

TS2903 has an open-collector output buffer. This allows the output to be pulled to any voltage rail up to 36V, regardless of the supply voltage. Such open-collector output stage makes the device compatible with transistor-transistor logic (TTL) as well as capable of driving a minimal 16mA current load such as lamps and relays.

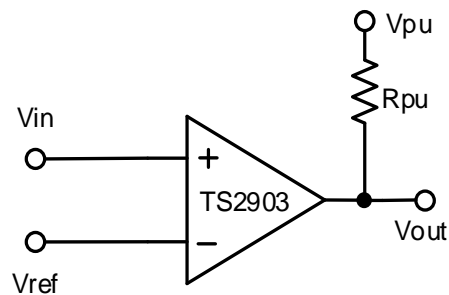
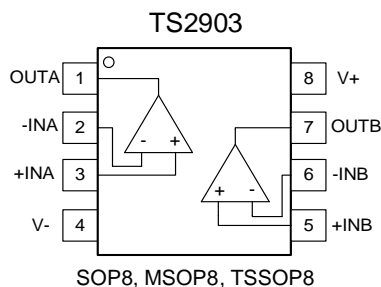

ORDERING INFORMATION

Model	Part Number	Eco Plan	Package	CMP	Container, Pack Qty
TS2903	TS2903SOP8R	RoHS	SOP8	2	Reel, 2500
TS2903	TS2903MSOP8R	RoHS	MSOP8	2	Reel, 3000
TS2903	TS2903TSSOP8R	RoHS	TSSOP8	2	Reel, 4000

RECOMMENDED OPERATING CONDITIONS

Parameter	Min	Max	Unit
Supply Voltage Range	2	36	V
Operating Temperature Range	-40	125	°C

ABSOLUTE MAXIMUM RATINGS

Over operating free-air temperature range (unless otherwise noted) ⁽¹⁾

Parameter	Min	Max	Unit
Supply Voltage		40	V
Input Terminal Voltage	(V-) - 0.3	(V+) + 0.3	V
Differential Input Voltage		40	V
Input Current		50	mA
Junction Temperature		150	°C
Storage Temperature Range	-65	150	°C
Lead Temperature (Soldering, 10s)		260	°C

- (1) Stresses beyond those listed under “Absolute Maximum Ratings” may cause permanent damage to the device. This is a stress rating only and functional operation of the device at these or any other conditions beyond those indicated in the operational sections of this specification is not implied. Exposure to absolute maximum rating conditions for extended periods may affect device reliability.

ESD CAUTION



ESD (electrostatic discharge) sensitive device
Charged devices and circuit boards can discharge without detection. Although this product features patented or proprietary protection circuitry, damage may occur on devices subjects to high energy ESD. Therefore, proper ESD precautions should be taken to avoid performance degradation or loss of functionality.

ELECTRICAL CHARACTERISTICS

Boldface limits apply over the specified temperature range, $T_A = -40^{\circ}\text{C}$ to $+125^{\circ}\text{C}$.

At $T_A = +25^{\circ}\text{C}$, $V_S = 5\text{V}$ (unless otherwise noted)

Parameter	Operating Conditions	Min	Typ	Max	Unit
V_S Power Supply Voltage		2		36	V
I_S Supply Current	$V_S = 5\text{V}$, $I_{OUT} = 0$, $R_{PU} = \infty$ $T_A = -40^{\circ}\text{C}$ to $+125^{\circ}\text{C}$		0.6	1	mA
	$V_S = 30\text{V}$, $I_{OUT} = 0$, $R_{PU} = \infty$ $T_A = -40^{\circ}\text{C}$ to $+125^{\circ}\text{C}$		0.7	1.7	mA
Input Characteristics					
V_{OS} Input Offset Voltage	$V_S = 5\text{V}$ to 30V , $V_O = 1.4\text{V}$, $R_S = 0\Omega$ $T_A = -40^{\circ}\text{C}$ to $+85^{\circ}\text{C}$ $T_A = -40^{\circ}\text{C}$ to $+125^{\circ}\text{C}$		1	5	mV
I_B Input Bias Current	I_{IN+} or I_{IN-} with Output in Linear Range $T_A = -40^{\circ}\text{C}$ to $+125^{\circ}\text{C}$		25	250	nA
I_{OS} Input Offset Current	$I_{IN+} - I_{IN-}$ $T_A = -40^{\circ}\text{C}$ to $+125^{\circ}\text{C}$		25	50	nA
G_V Voltage Gain	$V_{CC} = 15\text{V}$, $R_L \geq 15\text{k}\Omega$, $V_O = 1\text{V}$ to 11V	50	200		V/mV
V_{CM} Input Common Mode Voltage Range	$V_S = 30\text{V}$ (Note 1) $T_A = -40^{\circ}\text{C}$ to $+125^{\circ}\text{C}$	0		(V+) - 1.5	V
				(V+) - 2	V
Output Characteristics					
V_{OL} Saturation Voltage	$V_{IN-} = 1\text{V}$, $V_{IN+} = 0\text{V}$, $I_{OUT} = -4\text{mA}$ $T_A = -40^{\circ}\text{C}$ to $+125^{\circ}\text{C}$		200	400	mV
I_{OSC} Output Sink Current	$V_{IN-} = 1\text{V}$, $V_{IN+} = 0\text{V}$, $V_O = 1.5\text{V}$	6	16		mA
I_{lk} Output Leakage Current	$V_{IN-} = 0\text{V}$, $V_{IN+} = 1\text{V}$ $V_O = 5\text{V}$ $V_O = 30\text{V}$, $T_A = -40^{\circ}\text{C}$ to $+125^{\circ}\text{C}$		0.1		nA
				1	μA
Dynamic Performance					
Large Signal Response Time	$V_{IN} = \text{TTL Logic Swing}$, $V_{REF} = 1.4\text{V}$ $V_{PU} = 5\text{V}$, $R_{PU} = 5.1\text{k}\Omega$		300		nS
Response Time	$V_{PU} = 5\text{V}$, $R_{PU} = 5.1\text{k}\Omega$ (Note 2)		1.3		μS
Temperature Range					
θ_{JA}	Specified Range	-40		+125	$^{\circ}\text{C}$
	Operating Range	-40		+150	$^{\circ}\text{C}$
	Storage Range	-65		+150	$^{\circ}\text{C}$
	Thermal Resistance				
	SOP8			108	$^{\circ}\text{C/W}$
	TSSOP8			179	$^{\circ}\text{C/W}$
MSOP8			150	$^{\circ}\text{C/W}$	

Notes:

- The input common-mode voltage of either input signal voltage should not be allowed to go negatively by more than 0.3V (at $+25^{\circ}\text{C}$). The upper end of the common-mode voltage range is $V_+ - 1.5\text{V}$ (at $+25^{\circ}\text{C}$), but either or both inputs can go to $+36\text{V}$ without damages, independent of the magnitude of the V_S .
- The response time specified is for a 100mV step input with 5mV overdrive (input offset voltage should be considered). For larger overdrive signals 300ns can be obtained, see typical performance characteristics.

TYPICAL CHARACTERISTICS

At $T_A = +25^\circ\text{C}$, $V_S = 5\text{V}$, $R_{PU} = 15\text{k}\Omega$ (unless otherwise noted)

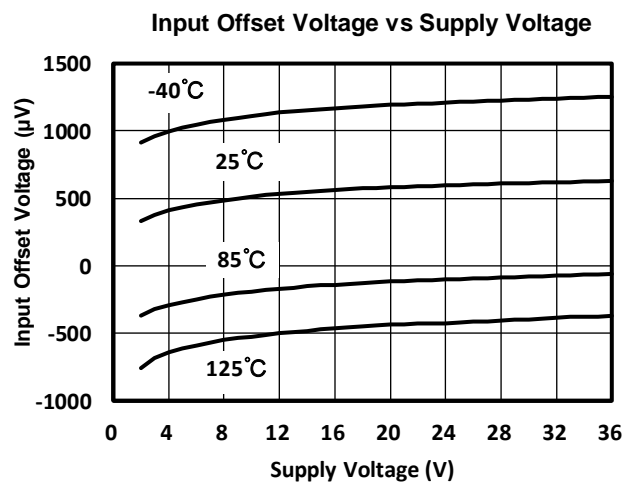
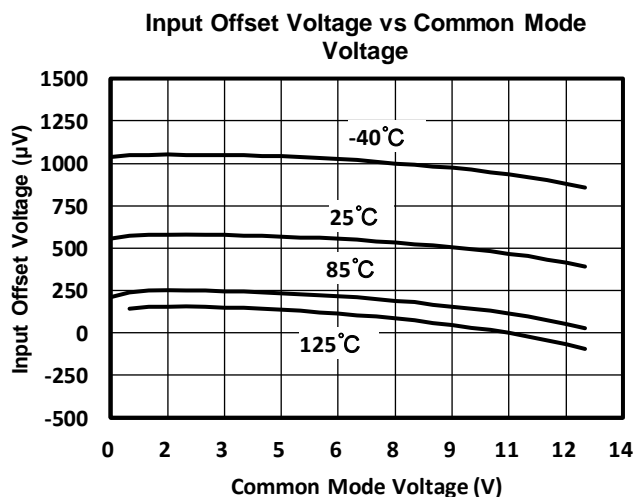
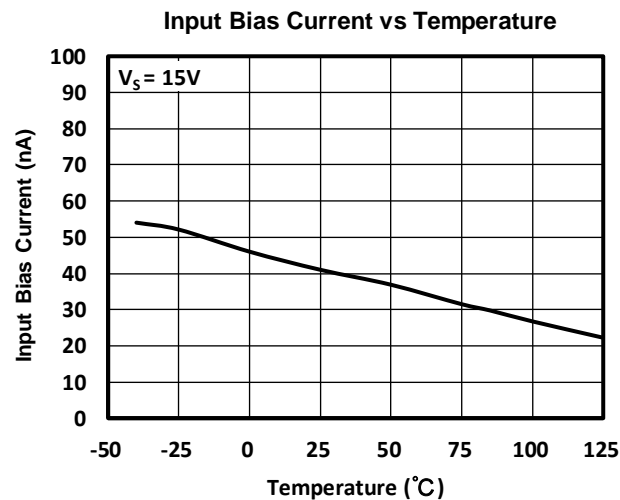
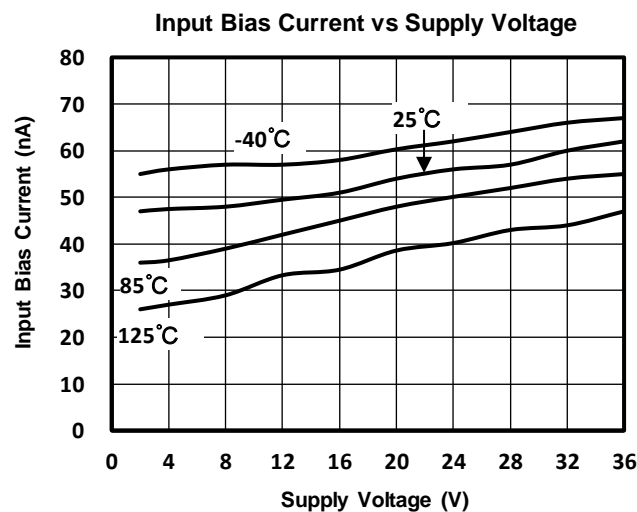
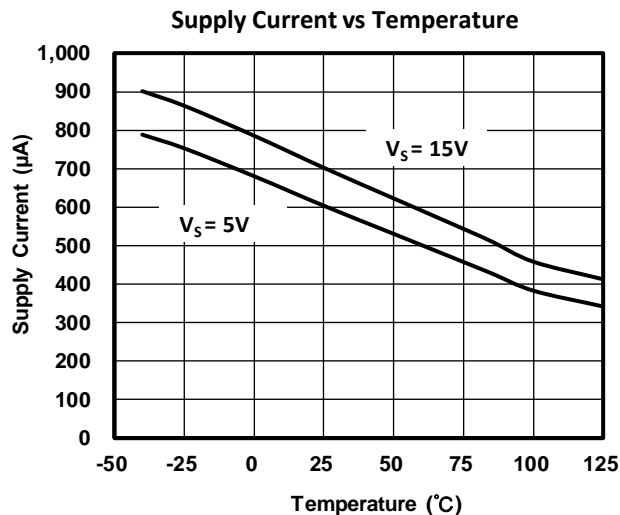
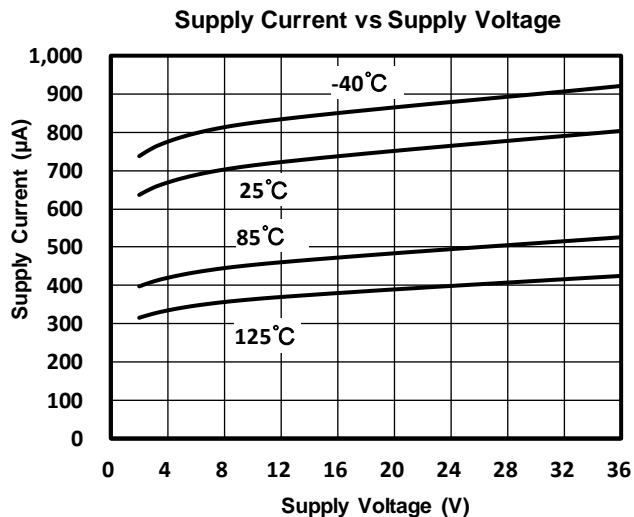

TYPICAL CHARACTERISTICS (CONTINUE)

At $T_A = +25^\circ\text{C}$, $V_S = 5\text{V}$, $R_{PU} = 15\text{k}\Omega$ (unless otherwise noted)

Response Time-Negative Transition

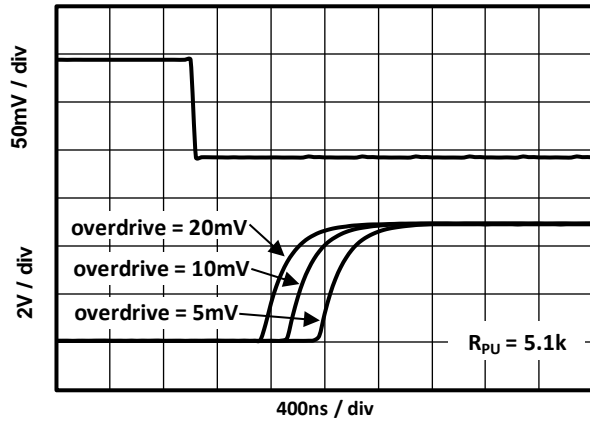

Response Time-Positive Transition

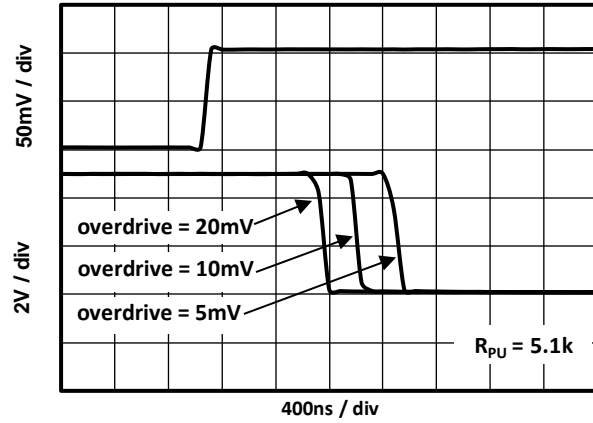

Output Voltage Swing vs Output Current

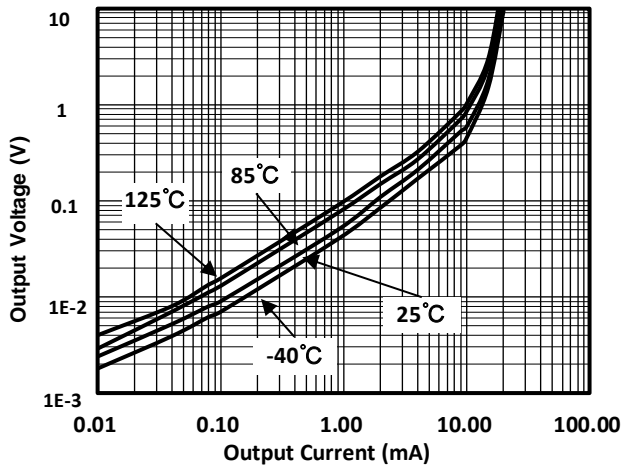

TYPICAL APPLICATION CIRCUIT

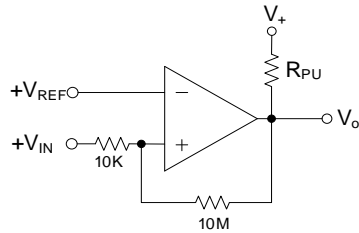

Non-Inverting Comparator with Hysteresis

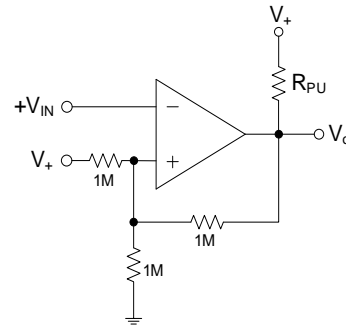

Inverting Comparator with Hysteresis

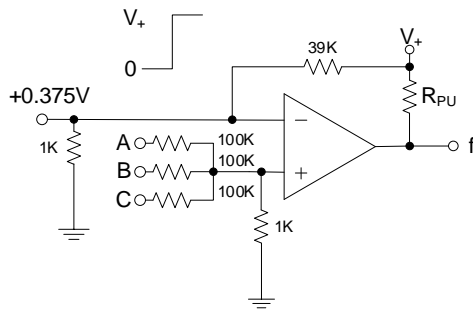

AND Gate

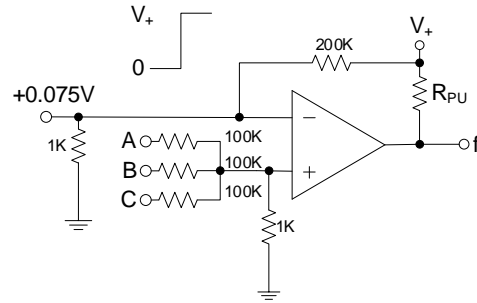

OR Gate

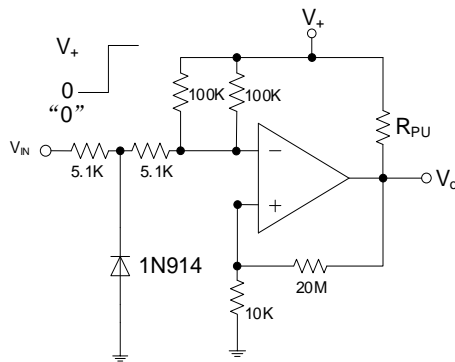

Zero Crossing Detector

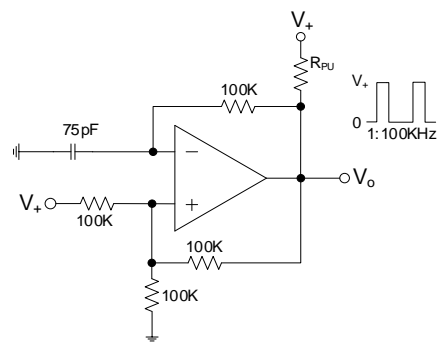

Square Wave Oscillator

MECHANICAL DIMENSIONS

SOP8 PACKAGE MECHANICAL DRAWING

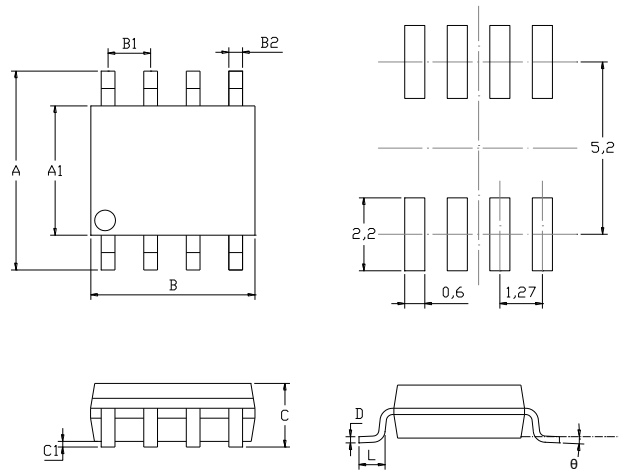

SOP8 PACKAGE MECHANICAL DATA

symbol	dimensions			
	millimeters		inches	
	min	max	min	max
A	5.800	6.200	0.228	0.244
A1	3.800	4.000	0.150	0.157
B	4.700	5.100	0.185	0.201
B1	1.270		0.050	
B2	0.330	0.510	0.013	0.020
C		1.750		0.069
C1	0.100	0.250	0.004	0.010
L	0.400	1.270	0.016	0.050
D	0.170	0.250	0.007	0.010
theta	0°	8°	0°	8°

MSOP8 PACKAGE MECHANICAL DRAWING

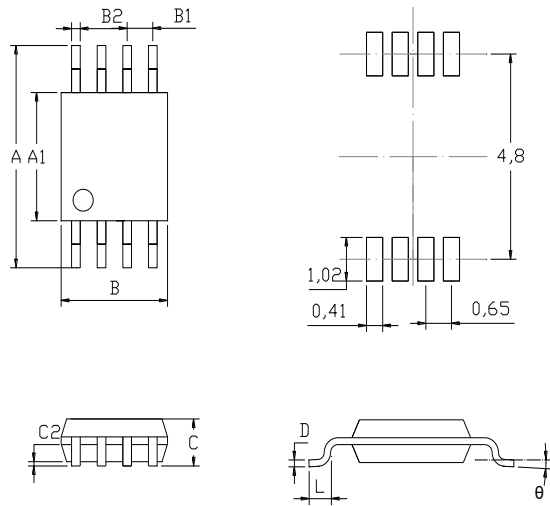

MSOP8 PACKAGE MECHANICAL SPECIFICATIONS

symbol	dimensions			
	millimeters		inches	
	min	max	min	max
A	4.750	5.050	0.187	0.199
A1	2.900	3.100	0.114	0.122
B	2.900	3.100	0.114	0.122
B1	0.650		0.026	
B2	0.250	0.380	0.010	0.015
C	0.820	1.100	0.032	0.043
C2	0.020	0.150	0.001	0.006
L	0.400	0.800	0.016	0.031
D	0.090	0.230	0.004	0.009
θ	0°	6°	0°	6°

TSSOP8 PACKAGE MECHANICAL DRAWING

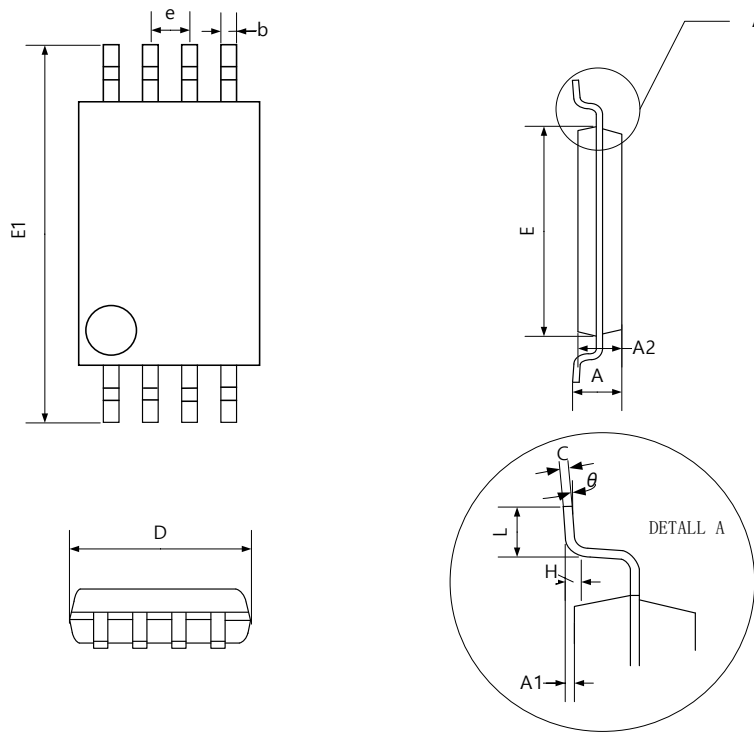

TSSOP8 PACKAGE MECHANICAL DATA

symbol	dimensions			
	millimeters		inches	
	min	max	min	max
D	2.900	3.100	0.114	0.122
E	4.300	4.500	0.169	0.177
b	0.190	0.300	0.007	0.012
c	0.090	0.200	0.004	0.008
E1	6.250	6.550	0.246	0.258
A		1.200		0.047
A2	0.800	1.000	0.031	0.039
A1	0.050	0.150	0.002	0.006
e	0.650		0.026	
L	0.500	0.007	0.020	0.028
H	0.250		0.010	
θ	1°	7°	1°	7°

TAPE AND REEL INFORMATION

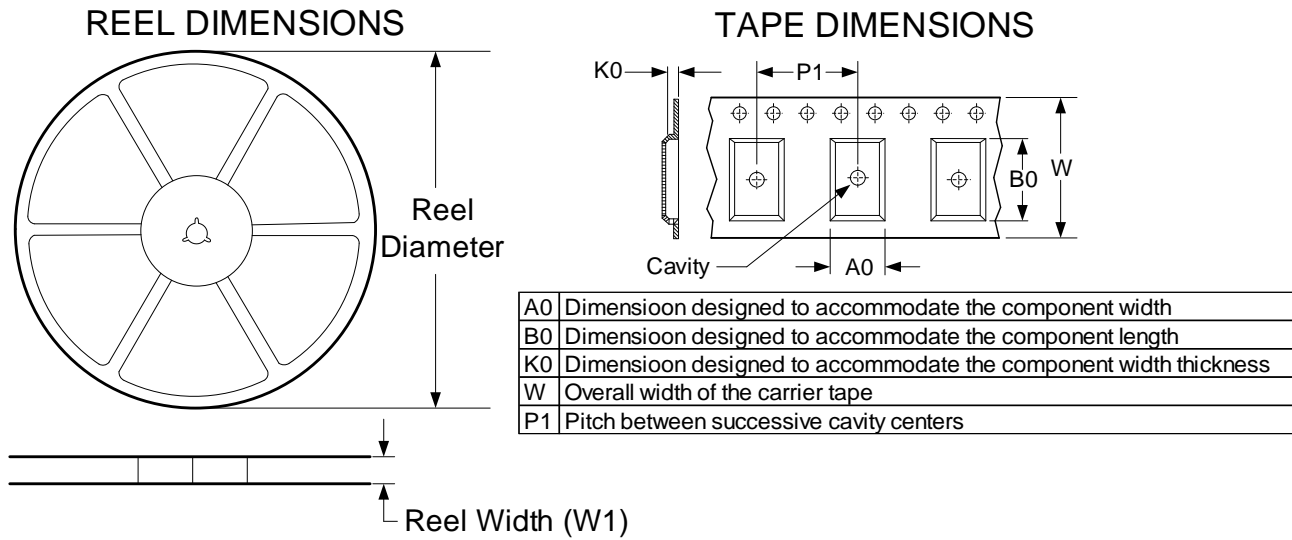

QUADRANT ASSIGNMENTS FOR PIN 1 ORIENTATION IN TAPE

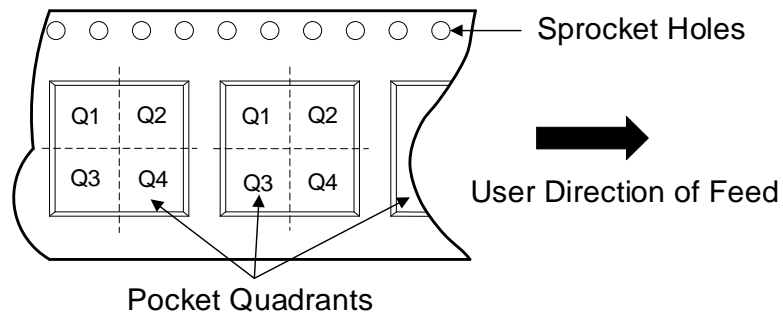

Device	Package Type	Pins	SPQ	Reel Diameter (mm)	Reel Width W1 (mm)	A0 (mm)	B0 (mm)	K0 (mm)	P1 (mm)	W (mm)	Pin1 Quadrant
TS2903SOP8R	SOP8	8	2500	330.0	12.4	6.4	5.4	2.1	8.0	12.0	Q1
TS2903MSOP8R	MSOP8	8	3000	330.0	12.4	5.2	3.3	1.5	8.0	12.0	Q1
TS2292ATSSOP8R	TSSOP8	8	4000	330.0	12.4	6.4	5.4	2.1	8.0	12.0	Q1

REVISION HISTORY

NOTE: Page numbers for previous revisions may be different from that of the current version.

2020/9/23 — REV KY1.0.0A to REV KY1.0.1A

Added notice to ABSOLUTE MAXIMUM RATINGS.....2

2021/1/28 — REV KY1.0.1A to REV KY1.1.1A

Updated ELECTRICAL CHARACTERISTICS.....3

2021/9/27 — REV KY1.1.1A to REV KY1.1.2A

Updated ELECTRICAL CHARACTERISTICS and TYPICAL APPLICATION CIRCUIT.....3

CONTACT INFORMATION

Trusignal Microelectronics

Phone: +86 512-65923982

Fax: +86 512-65923995

Email: support@kunyuanic.com; sales@kunyuanic.com