

10MHz, Rail-to-Rail I/O CMOS Operational Amplifier

FEATURES

- AEC-Q100 qualified for automotive applications
- Low Offset Voltage:
TS2278AQ-H: $\pm 0.5\text{mV}$ (MAX)
TS2278AQ: $\pm 3.5\text{mV}$ (MAX)
- High Gain: 102dB (TYP)
- High Gain Bandwidth Product: 10MHz
- Rail-to-Rail Input/Output
- Low I_B : 1pA (TYP)
- Low Supply Voltage: +2.5V to +5.5V
- Low Power Consumption: 1.1mA at 5V (Per Amplifier)
- Extended Temperature: -40°C to +125°C

PRODUCT DESCRIPTION

The TS2278AQ families of products are low noise, low voltage and low power operational amplifiers with high gain-bandwidth product of 10MHz and slew rate of 10V/ μs . The maximum input offset voltage is only 0.5mV (TS2278AQ-H) and the input common mode range extends beyond the supply rails.

TS2278AQ families of operational amplifiers are specified at the full temperature range of -40°C to +125°C under single or dual power supplies of 2.7V to 5.5V, however these products will operate under an extended supply range from 2.5V to 5.5V at a reduced temperatures range.

APPLICATIONS

- Signal Conditioning
- Current Sensor Amplifier
- Battery-Powered Applications
- Portable Devices
- Active Filtering
- Weight Scale Sensor
- Medical/Industrial Instrumentation
- Power Converter/Inverter

PIN ASSIGNMENTS

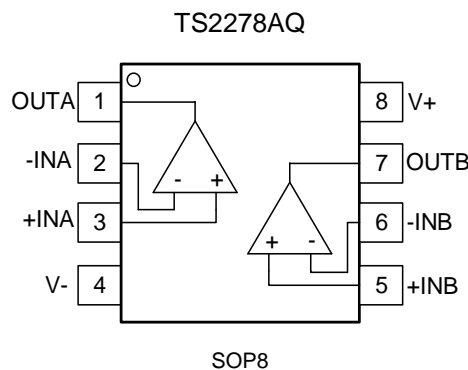

ORDERING INFORMATION

Model	Part Number	Eco Plan	Package	AMP	Container, Pack Qty
TS2278AQ-H	TS2278AQHSOP8R	RoHS	SOP8	2	Reel, 2500
TS2278AQ	TS2278AQ SOP8R	RoHS	SOP8	2	Reel, 2500

ABSOLUTE MAXIMUM RATINGS

Over operating free-air temperature range (unless otherwise noted) ⁽¹⁾

Parameter	Min	Max	Unit
Supply Voltage		7	V
Signal Input Terminal voltage	(V-) - 0.5	(V+) + 0.5	V
Operating Temperature	-40	150	°C
Junction Temperature		150	°C
Storage Temperature Range	-65	150	°C
Lead Temperature (Soldering, 10s)		260	°C
ESD HBM		±3000	V
ESD MM		±300	V
ESC CDM		±1000	V

(1) Stresses beyond those listed under “Absolute Maximum Ratings” may cause permanent damage to the device. This is a stress rating only and functional operation of the device at these or any other conditions beyond those indicated in the operational sections of this specification is not implied. Exposure to absolute maximum rating conditions for extended periods may affect device reliability.

ESD CAUTION



ESD (electrostatic discharge) sensitive device.

Charged devices and circuit boards can discharge without detection. Although this product features patented or proprietary protection circuitry, damage may occur on devices subjects to high energy ESD. Therefore, proper ESD precautions should be taken to avoid performance degradation or loss of functionality.

ELECTRICAL CHARACTERISTICS: $V_S = +2.7V$ to $+5.5V$

Boldface limits apply over the specified temperature range, $T_A = -40^{\circ}C$ to $+125^{\circ}C$.

At $T_A = +25^{\circ}C$, $V_S = 5V$, $R_L = 10k\Omega$ connected to $V_S / 2$, and $V_{OUT} = V_S / 2$ (unless otherwise noted)

Parameter	Operating Conditions		Min	Typ	Max	Unit
V_S Power Supply Voltage			2.7		5.5	V
I_S Supply Current (Per Amplifier)	$I_O = 0$			1.1	1.65	mA
PSRR Power Supply Rejection Ratio	$V_S = 2.7V$ to $5.5V$, $V_{CM} < (V+) - 2V$ $T_A = -40^{\circ}C$ to $+125^{\circ}C$			30	125	$\mu V/V$ $\mu V/V$
Input Characteristics						
V_{OS} Input Offset Voltage	TS2278AQ-H		-0.5		0.5	mV
	TS2278AQ		-3.5	1	3.5	mV
dV_{OS}/dT Average Drift				2.5		$\mu V/^{\circ}C$
I_B Input Bias Current				1		pA
I_{OS} Input Offset Current				1		pA
V_{CM} Input Common Voltage Range	$T_A = -40^{\circ}C$ to $+125^{\circ}C$		(V-) - 0.2		(V+) + 0.2	V
CMRR Common Mode Rejection Ratio	$V_S = 5.5V$	$(V-) - 0.2V < V_{CM} < (V+) - 2V$ $T_A = -40^{\circ}C$ to $+125^{\circ}C$	76	90		dB
		$(V-) - 0.2V < V_{CM} < (V+) + 0.2V$ $T_A = -40^{\circ}C$ to $+125^{\circ}C$	62	78		dB
			60			dB
AOL Open-Loop Gain	$V_S = 5V$, $R_L = 5k\Omega$ $(V-) + 0.125V < V_{out} < (V+) - 0.125V$ $T_A = -40^{\circ}C$ to $+125^{\circ}C$		96	102		dB
	$V_S = 5V$, $R_L = 100k\Omega$ $(V-) + 25mV < V_{out} < (V+) - 25mV$ $T_A = -40^{\circ}C$ to $+125^{\circ}C$		93	98		dB
			77			dB
Output Characteristics						
V_{OUT} Output Voltage Swing from Rail	$R_L = 100k\Omega$ $T_A = -40^{\circ}C$ to $+125^{\circ}C$			18	25	mV
	$R_L = 5k\Omega$ $T_A = -40^{\circ}C$ to $+125^{\circ}C$			100	125	mV
					125	mV
I_{OUT} Output Current				± 50		mA
R_{OUT} Open-Loop Output Impedance	$f = 1MHz$, $I_O = 0mA$			40		Ω
Dynamic Performance						
GBW Gain Bandwidth Product				10		MHz
SR Slew Rate	$G = +1$			10		V/ μs
t_s	Settling Time to 0.1%		$V_{OUT} = 2V$ step, $G = +1$		1	μs
	Settling Time to 0.01%		$V_{OUT} = 2V$ step, $G = +1$		1.5	μs
	Overload Recovery Time		$V_{in} * Gain > V_S$		0.2	μs

ELECTRICAL CHARACTERISTICS: $V_S = +2.7V$ to $+5.5V$ (CONTINUE)

Boldface limits apply over the specified temperature range, $T_A = -40^{\circ}C$ to $+125^{\circ}C$.

At $T_A = +25^{\circ}C$, $R_L = 10k\Omega$ connected to $V_S / 2$, and $V_{OUT} = V_S / 2$ (unless otherwise noted)

Parameter	Operating Conditions	Min	Type	Max	Unit
Noise Performance					
i_n Input Current Noise Density	$f = 10kHz$		4		fA/\sqrt{Hz}
e_n Input Voltage Noise Density	$f = 10kHz$		15		nV/\sqrt{Hz}
V_{noise} Input Voltage Noise	$f = 0.1Hz$ to $10Hz$		6		μV_{pp}
Temperature Range					
θ_{JA}	Specified Range	-40		+125	$^{\circ}C$
	Operating Range	-50		+150	$^{\circ}C$
	Storage Range	-65		+150	$^{\circ}C$
	Thermal Resistance				
	SOT-353		270		$^{\circ}C/W$
	SOP8 , MSOP8		150		$^{\circ}C/W$

TYPICAL CHARACTERISTICS

At $T_A = +25^\circ\text{C}$, $R_L = 10\text{k}\Omega$ connected to $V_S / 2$, and $V_{OUT} = V_S / 2$ (unless otherwise noted)

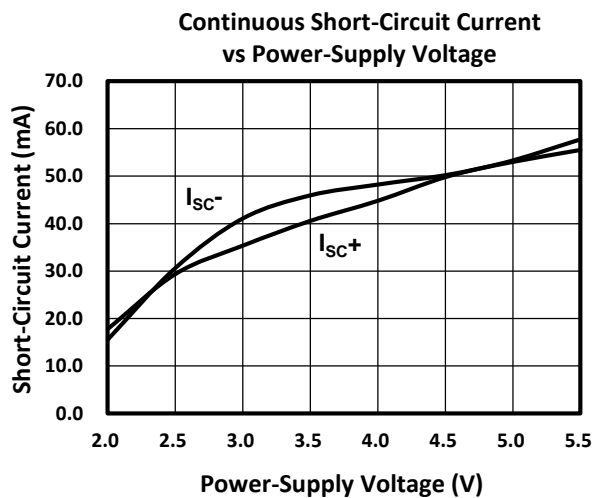
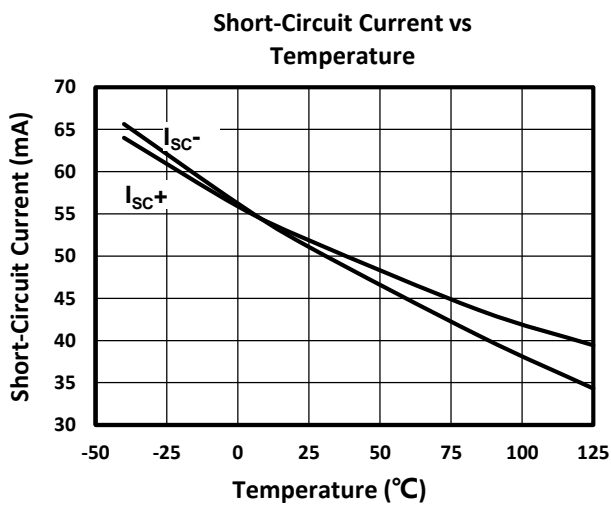
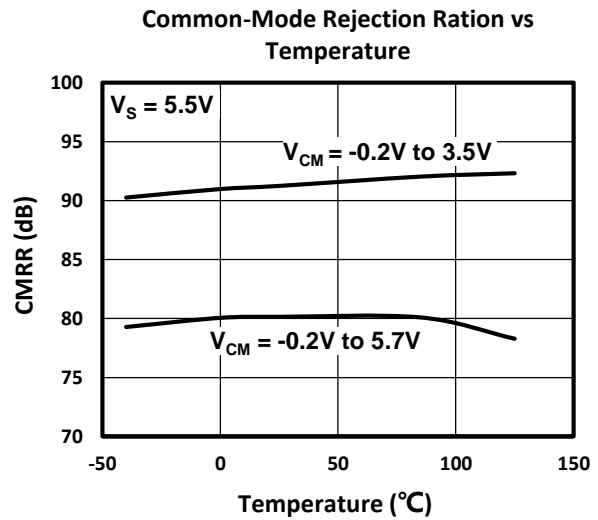
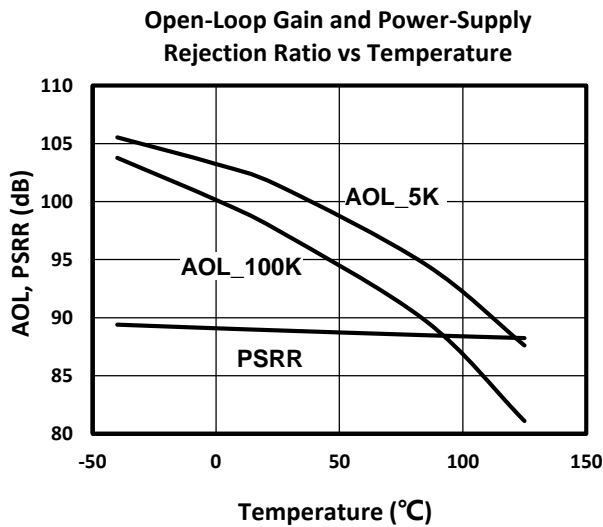
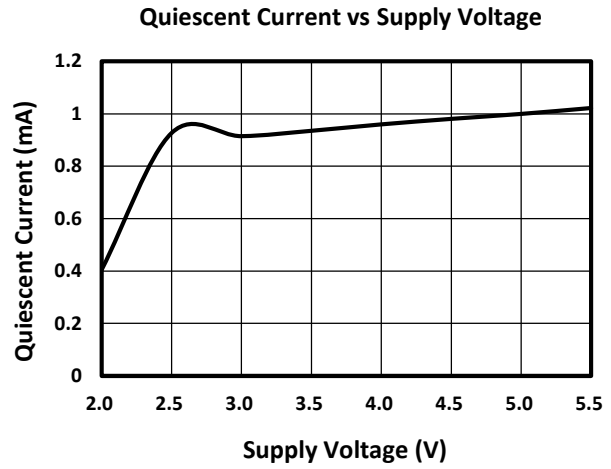
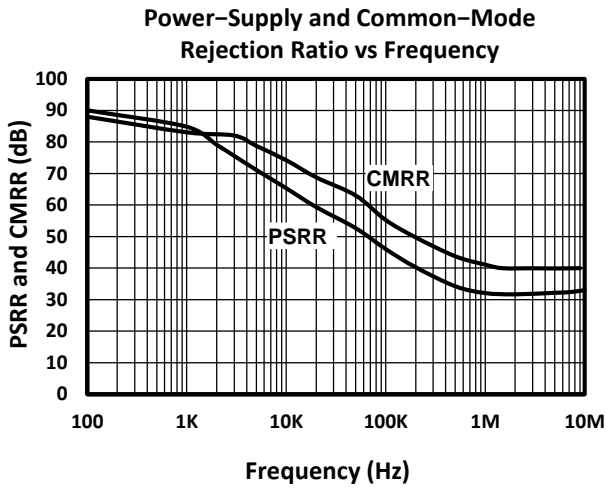

TYPICAL CHARACTERISTICS (CONTINUE)

At $T_A = +25^\circ\text{C}$, $R_L = 10\text{k}\Omega$ connected to $V_S / 2$, and $V_{OUT} = V_S / 2$ (unless otherwise noted)

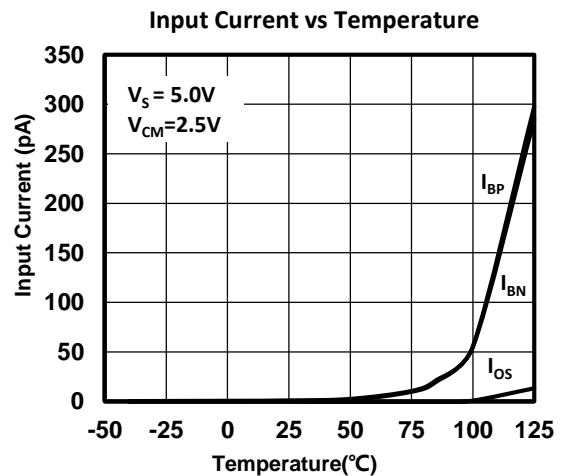
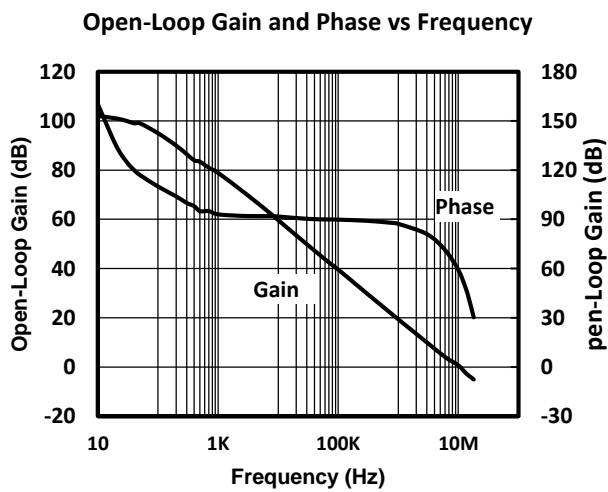
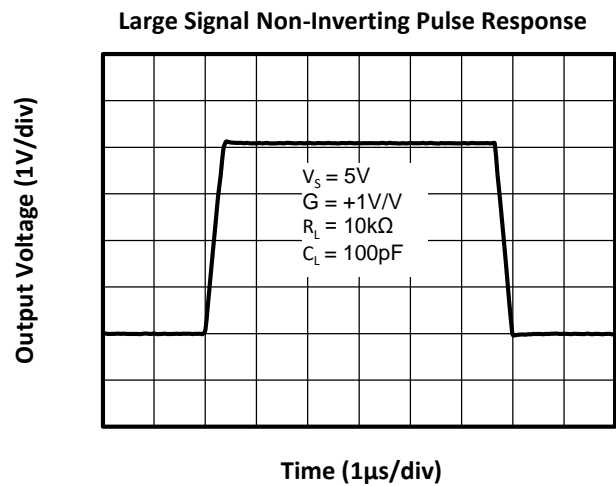
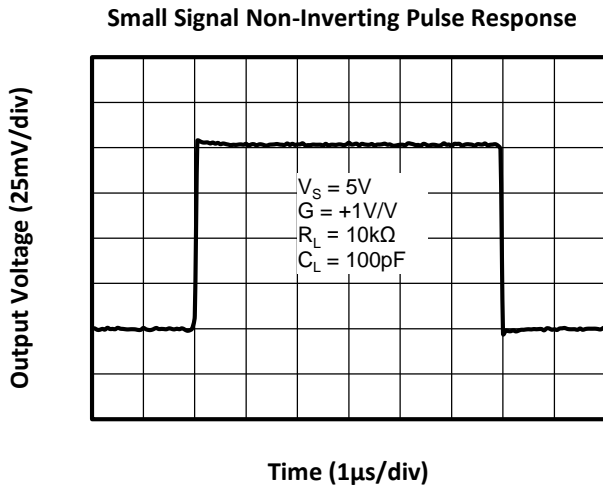
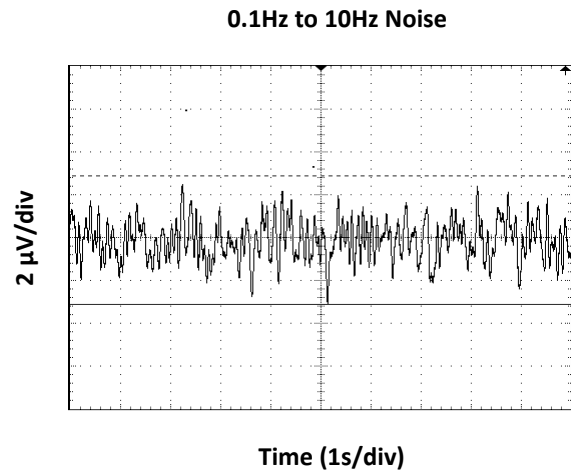
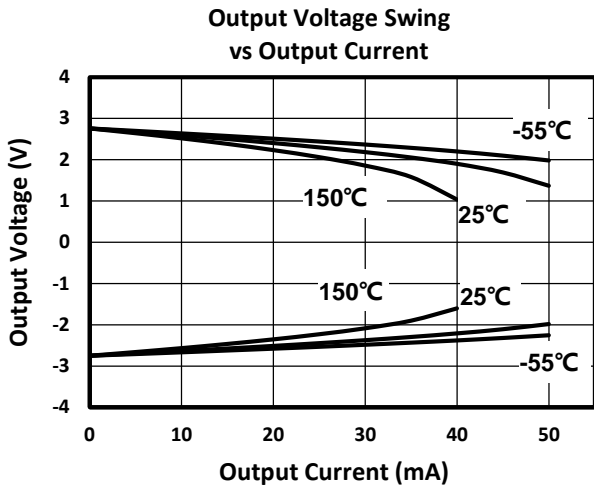

TYPICAL CHARACTERISTICS (CONTINUE)

At $T_A = +25^\circ\text{C}$, $R_L = 10\text{k}\Omega$ connected to $V_S / 2$, and $V_{OUT} = V_S / 2$ (unless otherwise noted)

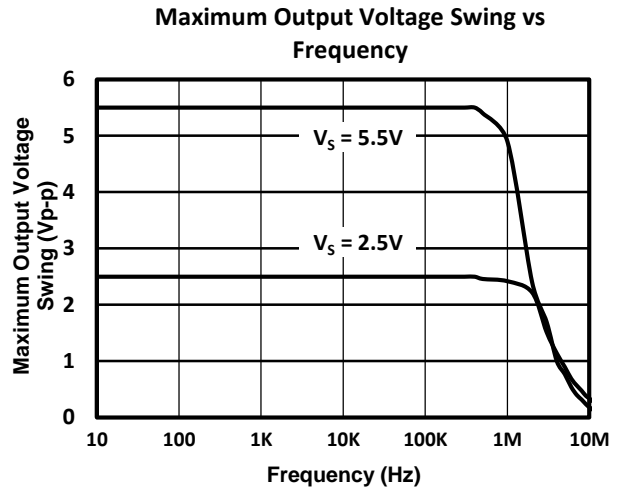
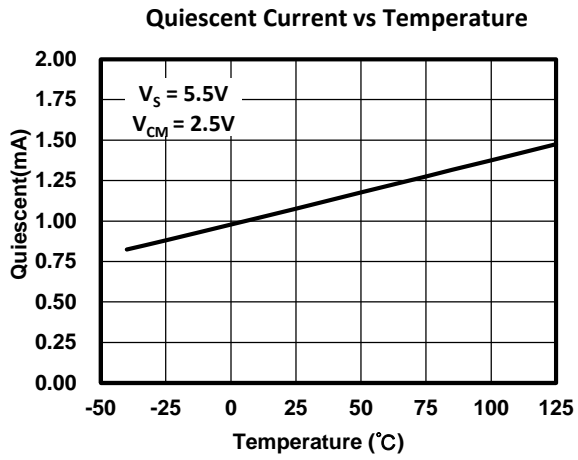

APPLICATION NOTES

The TS2177A and TS2178A families of op amps are suitable for a wide range of general-purpose applications. They provide Rail-to-rail input and output. Excellent ac performance makes them well-suited for audio and sensor applications. The input common-mode voltage range includes both rails, allowing the TS2177A and TS2178A families op amps to be used in bipolar and unipolar application. Rail-to-rail input and output swing significantly increases dynamic range, especially in low-supply applications. Power-supply pins should be bypassed with 0.1µF ceramic capacitors.

POWER SUPPLY

The TS2177A and TS2178A families operate from a single +2.5V to +5.5V supply or dual ±1.25V to ±2.75V supplies. For single supply operation, bypass the power supply +Vs with a 0.1µF capacitor which should be placed close to the +Vs pin. For dual-supply operation, both the +Vs and the -Vs supplies should be bypassed to ground with separate 0.1µF ceramic capacitors. 2.2µF tantalum capacitor can be added for better performance.

The TS2177A and TS2178A families are ideal for battery-powered instrumentation and handheld devices because it can operate at the end of discharge voltage of most popular batteries.

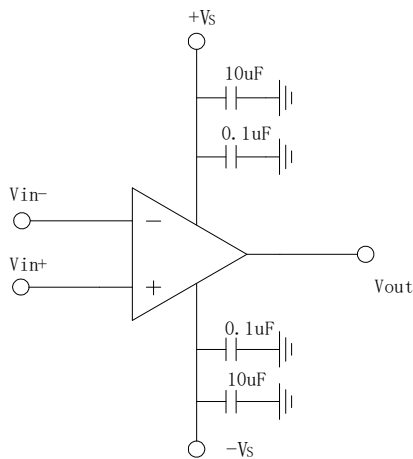

Figure1. Amplifier with Bypass Capacitors

DRIVING CAPACITIVE LOADS

The TS2177A and TS2178A families can directly drive 1000pF in unity-gain without oscillation. The unity-gain follower (buffer) is the most sensitive configuration to capacitive loading. Direct capacitive loading reduces the phase margin of amplifiers and this result in ringing or even oscillation. Applications

that require greater capacitive driving capability should use an isolation resistor between the output and the capacitive load like the circuit in Figure2. The isolation resistor R_{ISO} and the load capacitor C_L form a zero to increase stability. The bigger the R_{ISO} resistor value, the more stable V_{OUT} will be. Note that this method results in a loss of gain accuracy because R_{ISO} forms a voltage divider with the R_{LOAD} .

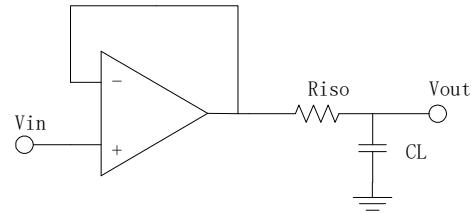

Figure 2. Indirectly Driving Heavy Capacitive Load

An improved circuit is shown in Figure 3. It provides DC accuracy as well as AC stability. R_f provides the DC accuracy by connecting the inverting signal with the output. C_f and R_{ISO} serve to counteract the loss of phase margin by feeding the high frequency component of the output signal back to the amplifier's inverting input, thereby preserving phase margin in the overall feedback loop.

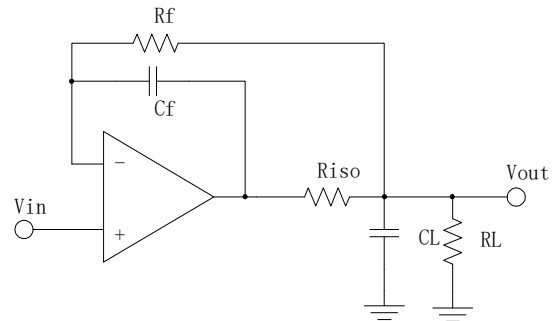

Figure 3. Indirectly Driving Heavy Capacitive Load with DC Accuracy

For non-buffer configuration, there are two other ways to increase the phase margin: (a) by increasing the amplifier's gain or (b) by placing a capacitor in parallel with the feedback resistor to counteract the parasitic capacitance associated with inverting node.

TYPICAL APPLICATIONS

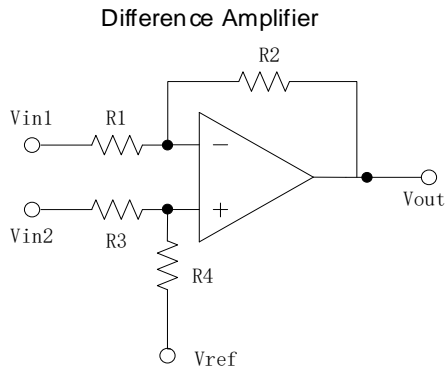

Figure 4. Differential Amplifier

The circuit shown in Figure 4 performs the difference function. If the resistor ratios are equal ($R4 / R3 = R2 / R1$) then $V_{out} = (V_{in2} - V_{in1}) \times R2 / R1 + V_{ref}$.

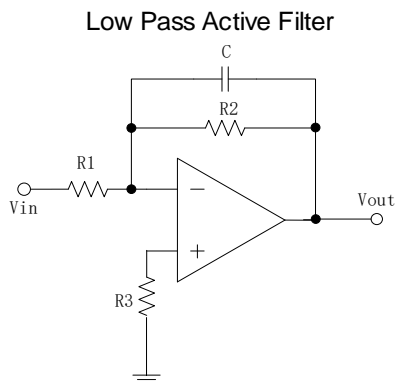

Figure 5. Low Pass Active Filter

The low pass filter shown in Figure 5 has a DC gain of $(-R2 / R1)$ and the -3dB corner frequency is $1/2\pi R2C$. Make sure the filter within the bandwidth of the amplifier. The Large values of feedback resistors can couple with parasitic capacitance and cause undesired effects such as ringing or oscillation in high-speed amplifiers. Keep resistors value as low as possible and consistent with output loading consideration.

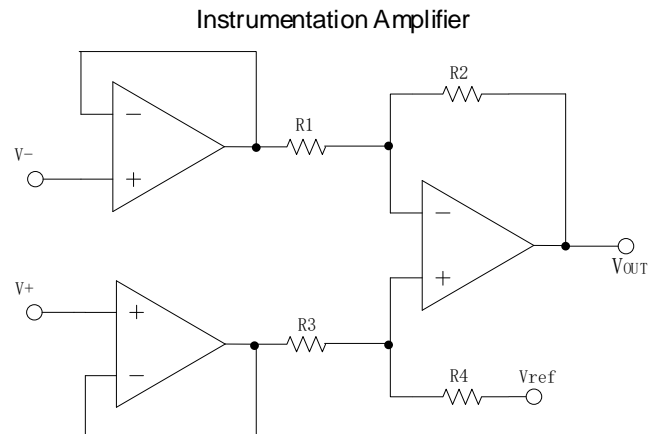
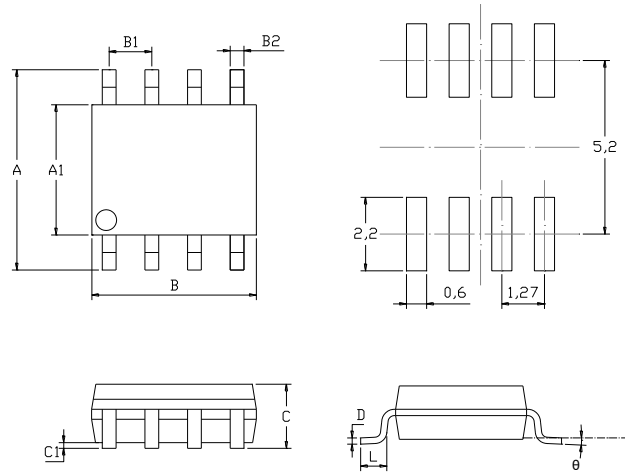

Figure 6. Instrumentation Amplifier

The circuit in Figure 6 performs the same function as that in Figure 4 but with the high input impedance.

MECHANICAL DIMENSIONS

SOP8 PACKAGE MECHANICAL DRAWING



SOP8 PACKAGE MECHANICAL DATA

symbol	dimensions			
	millimeters		inches	
	min	max	min	max
A	5.800	6.200	0.228	0.244
A1	3.800	4.000	0.150	0.157
B	4.700	5.100	0.185	0.201
B1	1.270		0.050	
B2	0.330	0.510	0.013	0.020
C		1.750		0.069
C1	0.100	0.250	0.004	0.010
L	0.400	1.270	0.016	0.050
D	0.170	0.250	0.007	0.010
theta	0°	8°	0°	8°

TAPE AND REEL INFORMATION

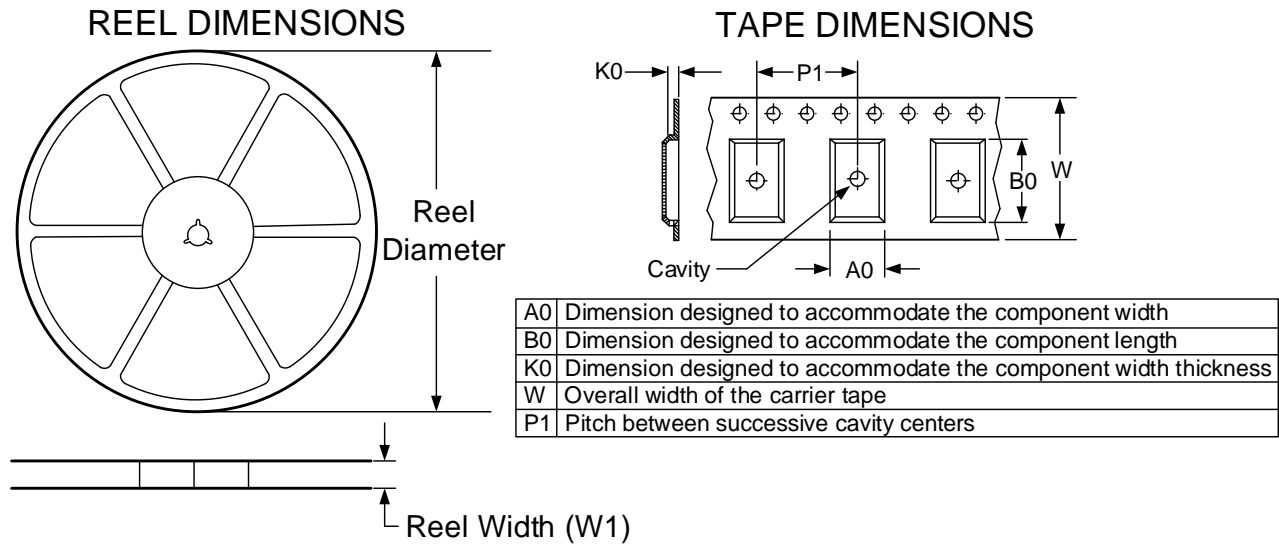

QUADRANT ASSIGNMENTS FOR PIN 1 ORIENTATION IN TAPE

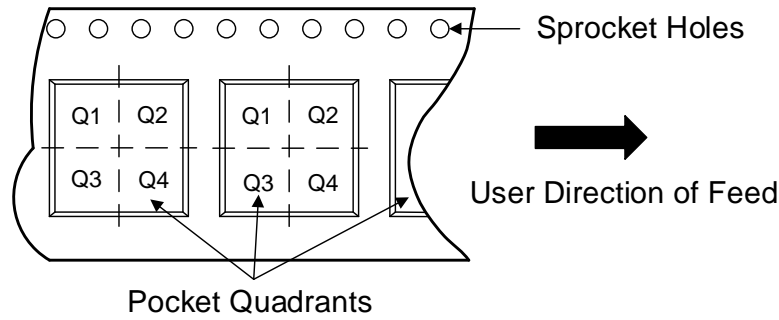

Device	Package Type	Pins	SPQ	Reel Diameter (mm)	Reel Width W1 (mm)	A0 (mm)	B0 (mm)	K0 (mm)	P1 (mm)	W (mm)	Pin1 Quadrant
TS2278AQHSOP8R	SOP8	8	2500	330.0	12.4	6.4	5.4	2.1	8.0	12.0	Q1
TS2278AQ SOP8R	SOP8	8	2500	330.0	12.4	6.4	5.4	2.1	8.0	12.0	Q1

REVISION HISTORY

NOTE: Page numbers for previous revisions may be different from that of the current version.

2020/10/24 — REV KY0.0.0A

This Version Is Informal.....All Pages

2023/3/30 — REV KY0.0.0A to REV KY1.0.0A

Adjust Page Format.....All Pages

Add AEC-Q100 qualified for automotive applications.....1

CONTACT INFORMATION

Trusignal Microelectronics

Phone: +86 512-65923982

Fax: +86 512-65923995

Email: support@kunyuanic.com; sales@kunyuanic.com